

Group Exercise 1:

Bicycle and Pedestrian Accommodations

- CAG members at each table should take about 20 minutes to review and discuss the bicycle and pedestrian facilities, locations and crossing information.
- A Toolbox and Checklist for Bicycle and Pedestrian Accommodations will be provided
- The following questions should be addressed during the discussion:
 - *What Bicycle and Pedestrian facilities do you prefer?*
 - *Where would you like the Bicycle and Pedestrian facilities to be? What should they connect?*











Group Exercise 1: Bicycle and Pedestrian Accommodations

- The CAG facilitator will then lead the overall group in a discussion of small group results.
- At the end of the exercise, the goal is to reach a general understanding of agreement for the draft preferred bicycle and pedestrian accommodations.
- The CAG will have an opportunity to modify the bicycle and pedestrian accommodations at the next CAG meeting based upon the transit element.



Bicycle & Pedestrian Facilities

	FACILITY	PROJECTED USERS PER HOUR	BICYCLE	PEDESTRIAN
Nothing	0' Wide			
Sidewalk	5' Wide			
One Way Shared Use Path	*6' Wide	<300		
	*7' Wide	>300		
Two Way Shared Use Path	*10' Wide	<300		
	*12' Wide	>300		

* MINIMUM OF 1, 10-12' TWO-WAY PATH OR 2, 6-7' ONE-WAY PATHS ARE REQUIRED PER IDOT



Bicycle & Pedestrian Locations

Crossing I-90

BARRINGTON LEFT

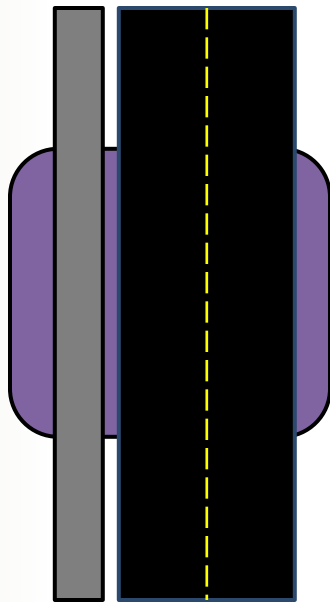

BARRINGTON RIGHT

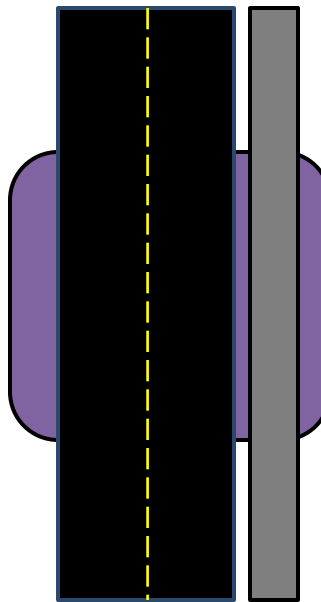

OFFSET

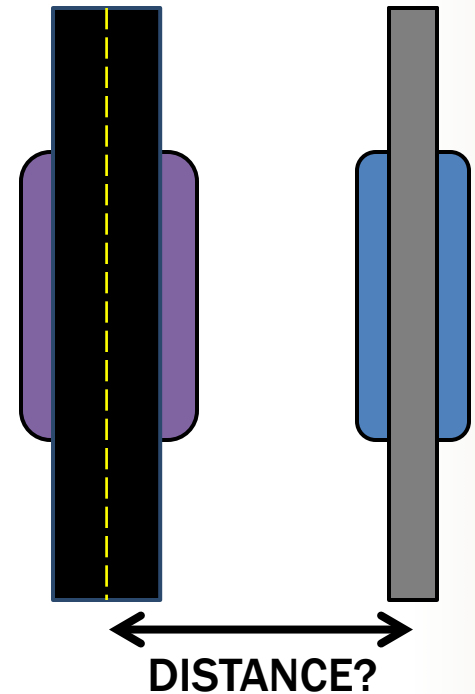

Bicycle & Pedestrian Locations

Crossing Barrington Road

STUDIO DRIVE

CENTRAL ROAD

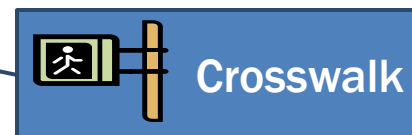

I-90



INTERCHANGE
TYPE

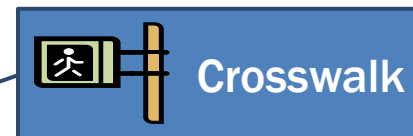

PRIVATE DRIVE

HASSELL ROAD



Bicycle & Pedestrian Crossings

GRADE	CROSSING	Description	Location Cost
AT-GRADE	Unprotected	Crosswalk without Traffic Signal	\$500 +/-
	Protected – Vehicular Signal	Crosswalk with pedestrian signal heads at an existing signalized vehicular crossing	\$2,500 +/-
	Protected – Pedestrian Activated Signal	Crosswalk with pedestrian and vehicular signal heads at an otherwise free flow ramp	\$16,000 +/-
GRADE SEPARATED	Underpass	Culvert underneath Ramp	\$250,000 +/-
	Overpass of Ramp	Bridge over Ramp	\$250,000 +/-
	Overpass of I-90 and Ramps	Bridge over I-90 and Ramps	\$800,000 +/-
	Overpass of I-90 at Huntington Blvd	Bridge over I-90 (Powerline Conflicts)	\$6,800,000 +/-

Potential Bike/Ped Impact Areas

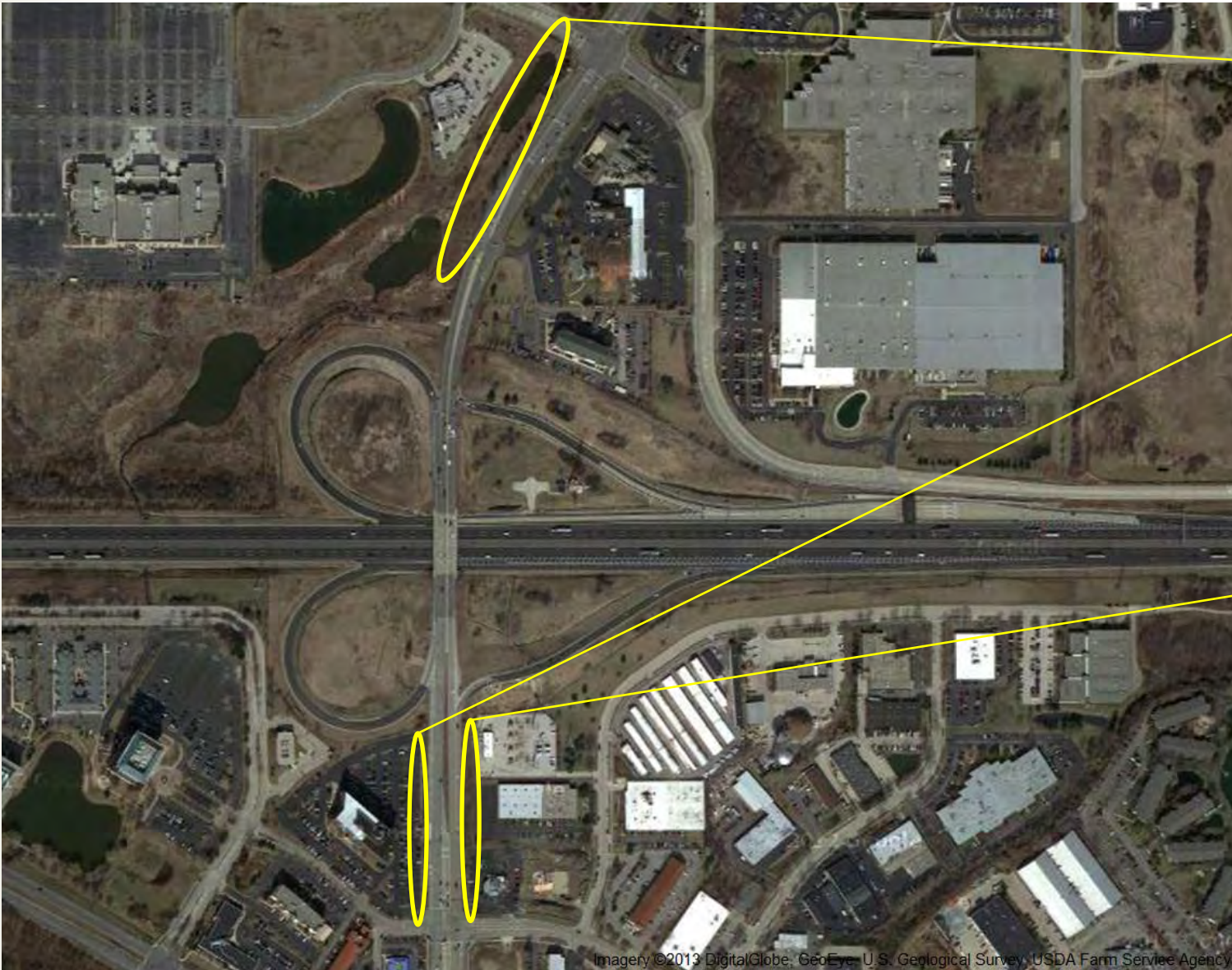

- Wetland and Floodplain Impacts near Studio Drive
- Parking Impacts at northwest corner of Hassell Road
- Parking and ROW Impacts at northeast corner of Hassell Road



CMT
CRAWFORD, MURPHY & TILLY, INC.
CONSULTING ENGINEERS
1220-03-03

MODEL NAME = Detail	DESIGNED -
FILE NAME = P19181143004_Parkway	DRAWN -
PLOT SCALE = 28.0000' / in.	CHECKED -
PLOT DATE = 1/29/2013 (6:57:50 PM)	DATE -

REVISION	REVISION
REVISION	REVISION
REVISION	REVISION

90
Barrington Road
at I-90 Interchange

VILLAGE OF HOFFMAN ESTATES

BICYCLE AND PEDESTRIAN ACCOMMODATIONS EXERCISE

SCALE:	SHEET	OF	SHEETS	STA.	TO	STA.

F.A.P. RT#	SECTION	COUNTY	TOTAL SHEET NO.
0362		COOK	4
		EXHIBIT	CO4, BPAE
		ILLINOIS FED. AID PROJECT	

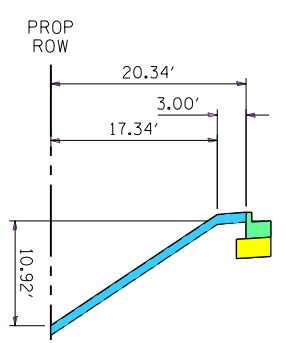
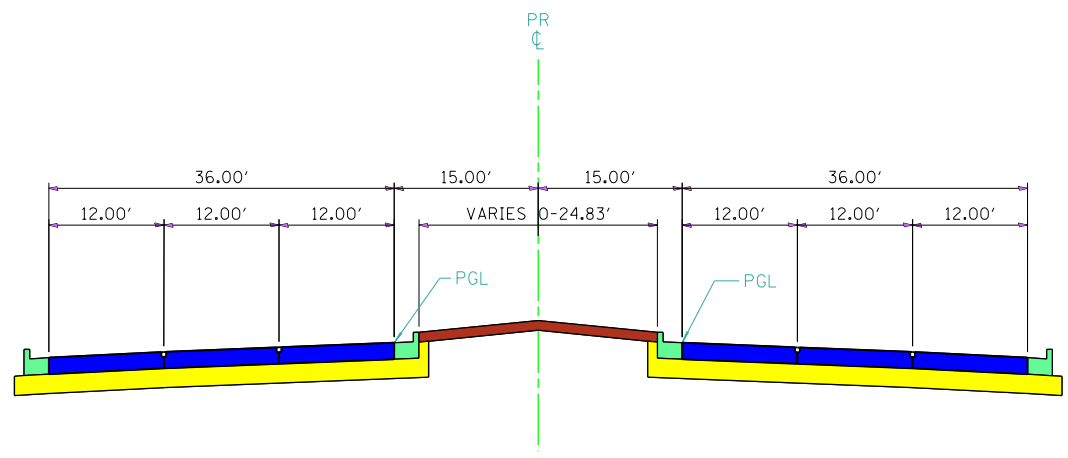

01

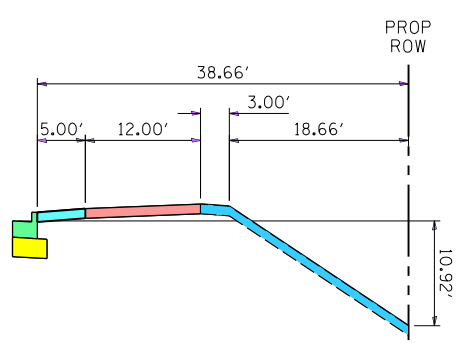

07

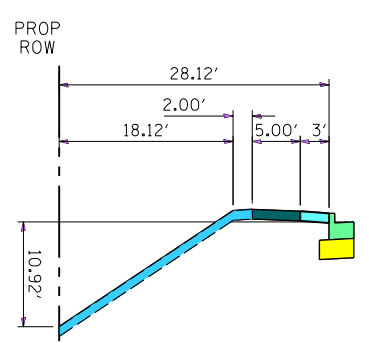

02

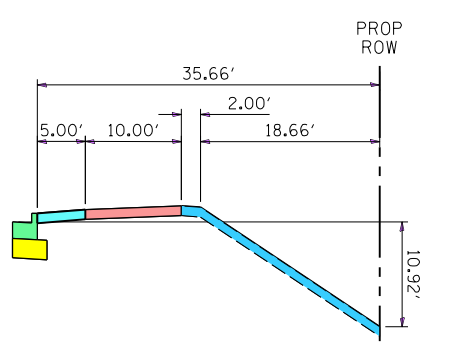

08

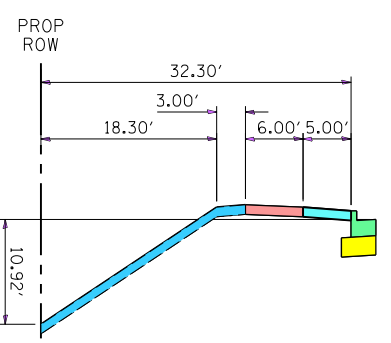

03

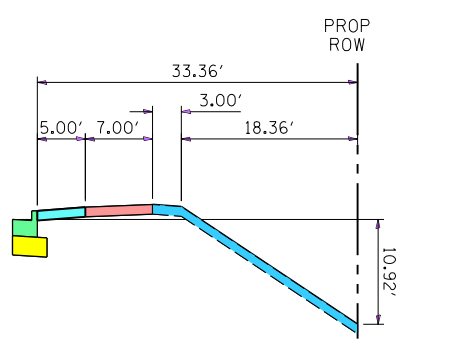

09

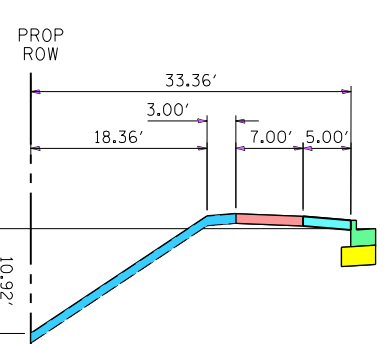

04

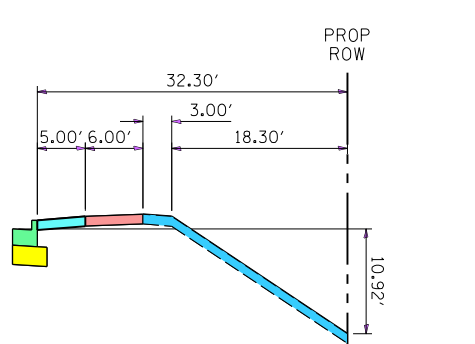

10

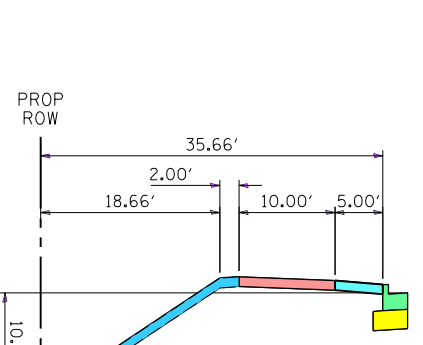

05

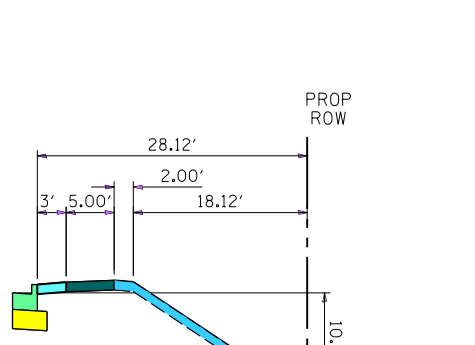

11

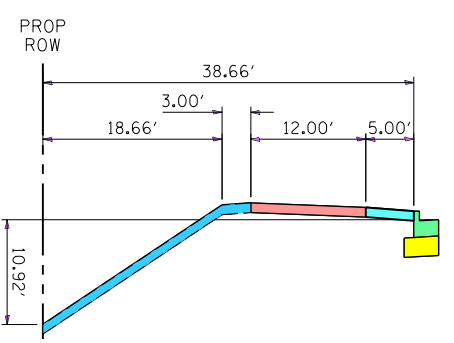

06

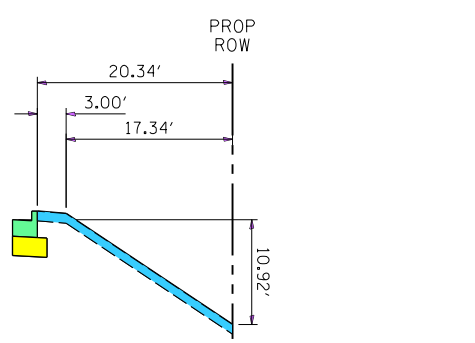

12